

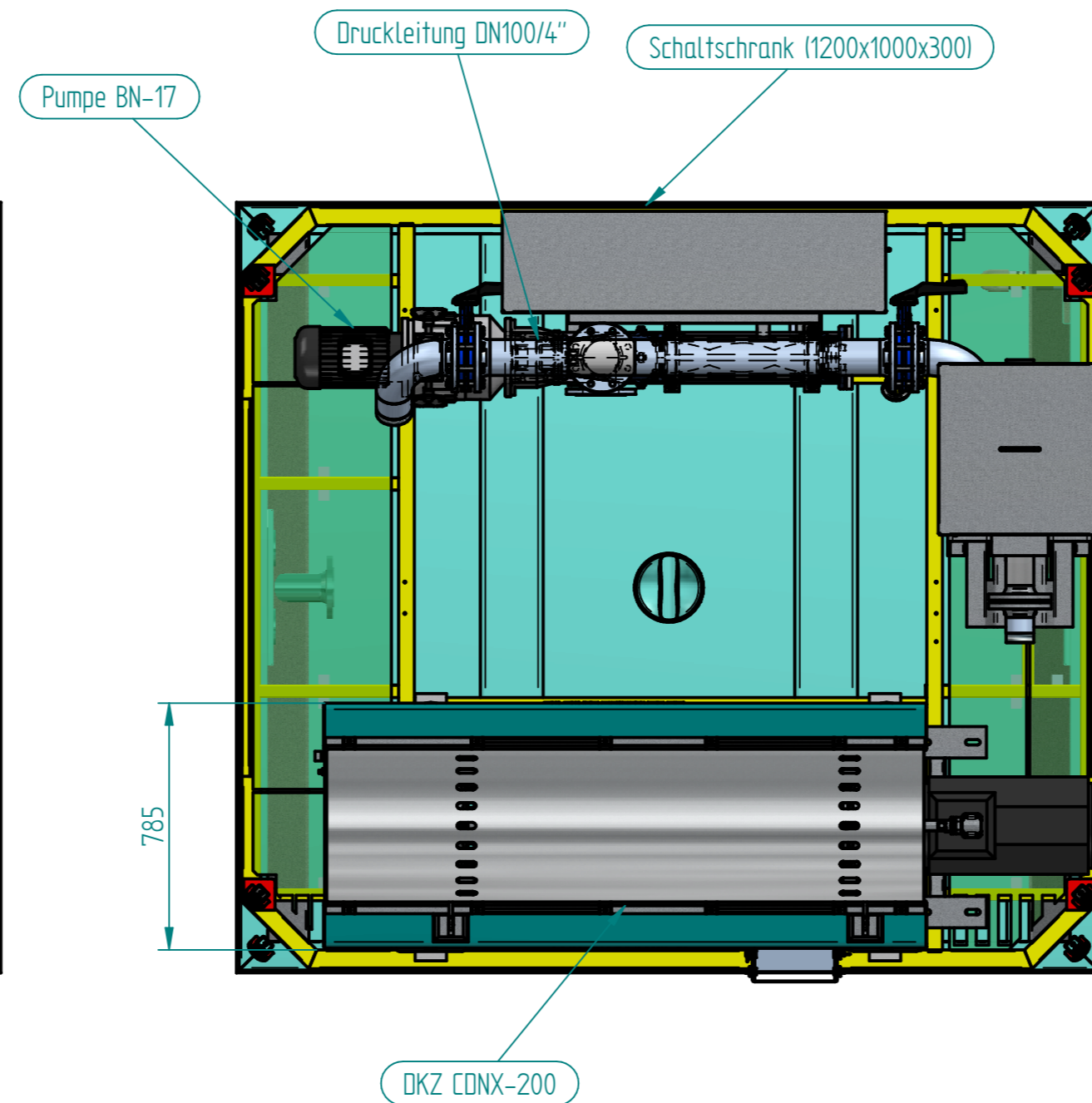

1:20

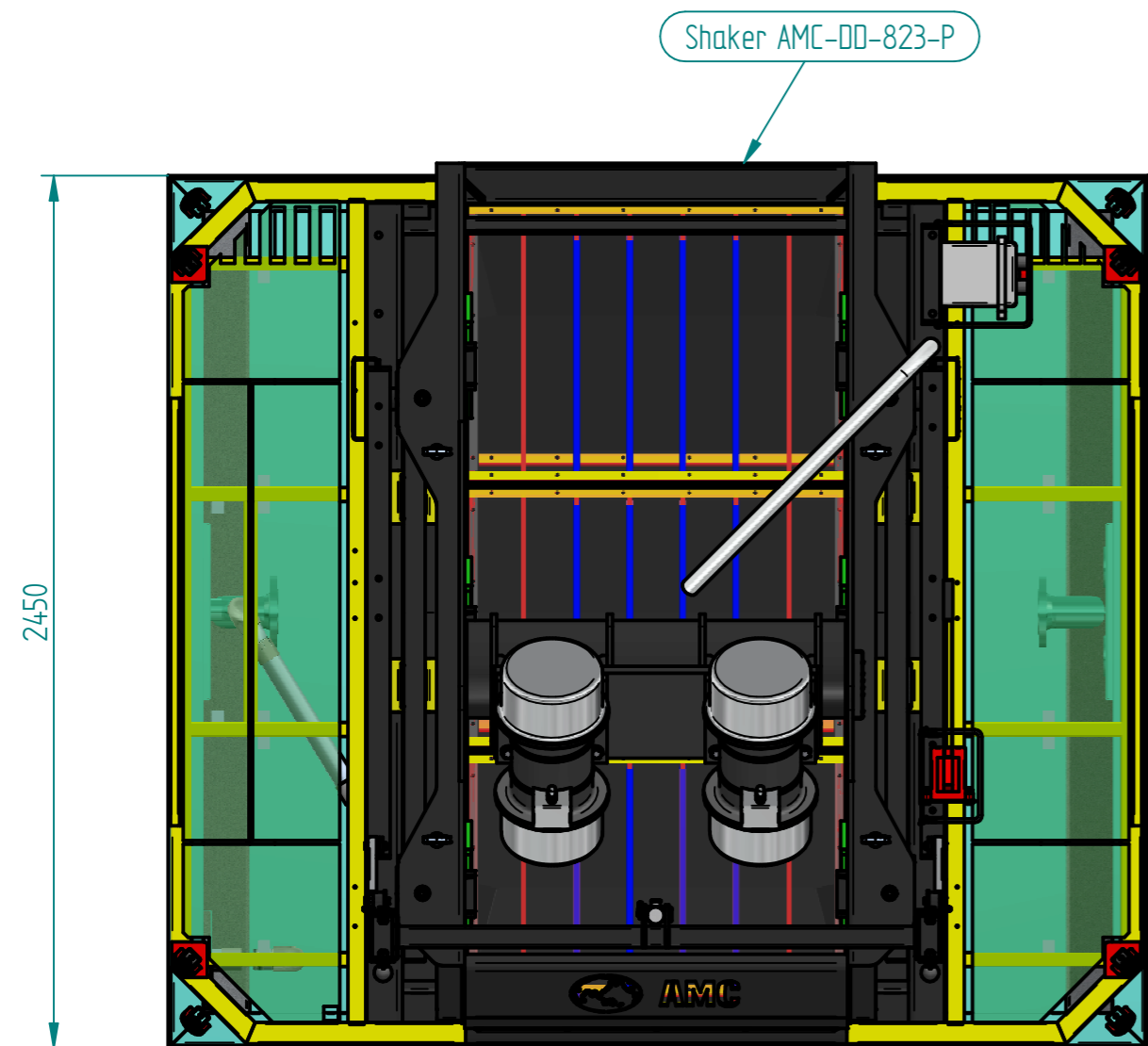
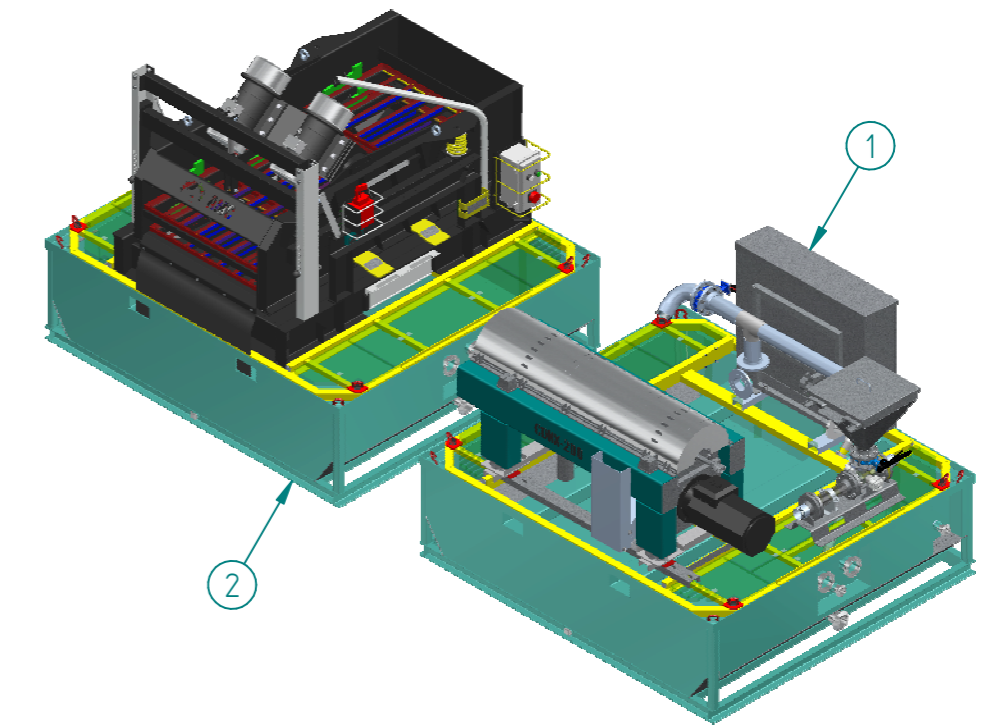
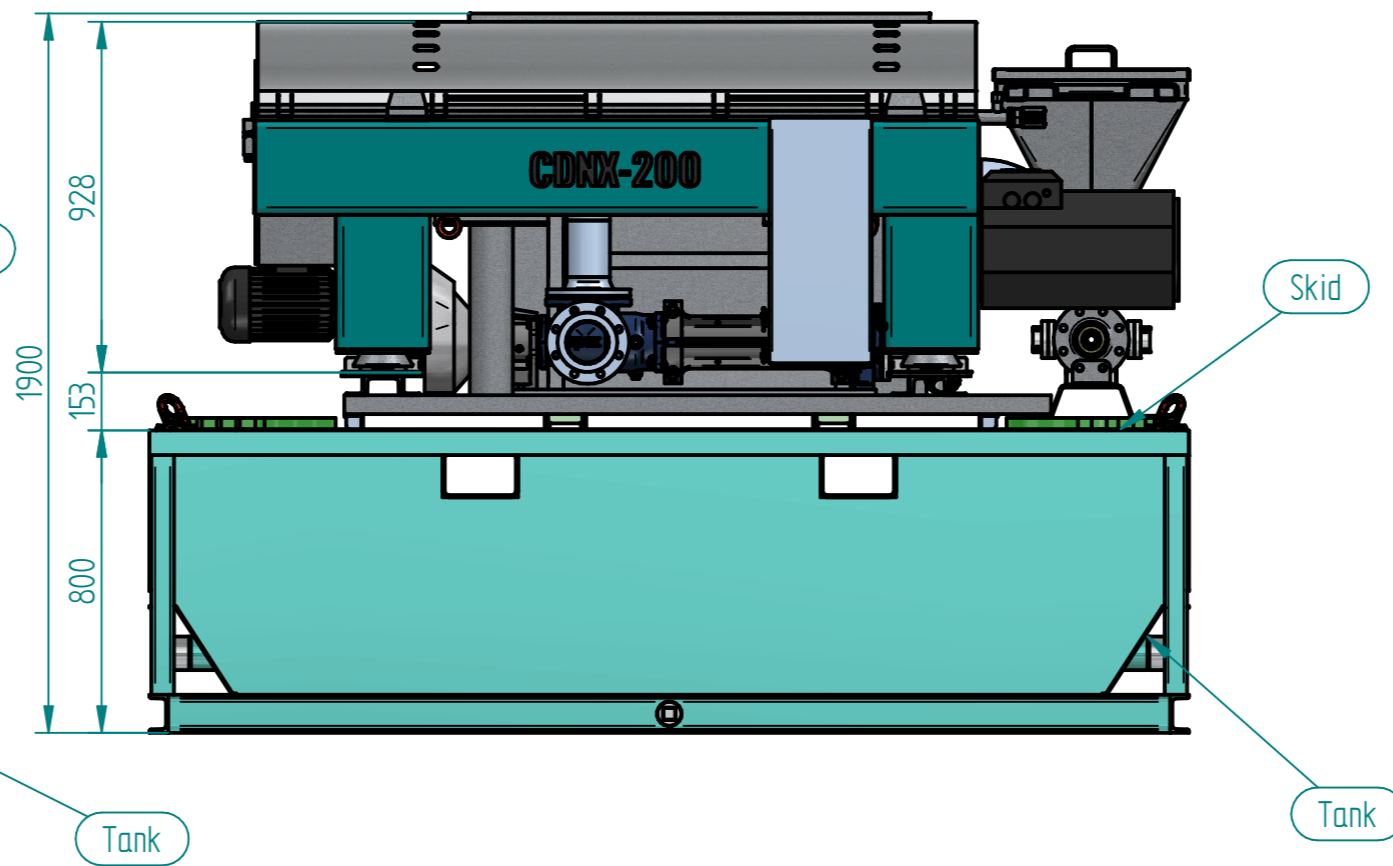

Pos.Nr.	Anz.	Z.Nr.	Titel	Mat.	Knz.	Index
1	1	MD-15-009-101	SRU-Modul-1Z-XL		B	
2	1	MD-15-009-102	SRU-Modul-2R-XL		B	

Allgemeintoleranzen DIN ISO 2768 - m		Name	Datum	Artikelnummer AMC: Fehler: Keine Referenz	
Mat.:	gezeichnet	christoph.jurc	07/23/15	Benennung: Modulare SRU-XL	
Schweißnahtvorbereitung DIN EN ISO 9692	geprüft	Schmidt-Dudek	-	Zeichnungsnummer: MD-15-009-100	
Kehlnähte: $a = 0,7 \times S_{min}$ bzw. $a = 0,4 \times S_{min}$ Kanten entgratet 0,3 x 45°		 AMC Germany GmbH Königsstraße 39 D-26180 Rasttefle Telefon: +49 (0) 4402 - 6950-0 Telefax: +49 (0) 4402 - 695099 www.amcoilandgas.com E-Mail: amc@eu.indeximtest.com		Darstellung:  REV Maßstab: 1:50 Gewicht: 0,000 kg Blatt 1 von 1	
In der Zeichnung	nach DIN ISO 1302	nach DIN 3141 R3	The index Group ALL rights reserved to AMC Germany GmbH		