

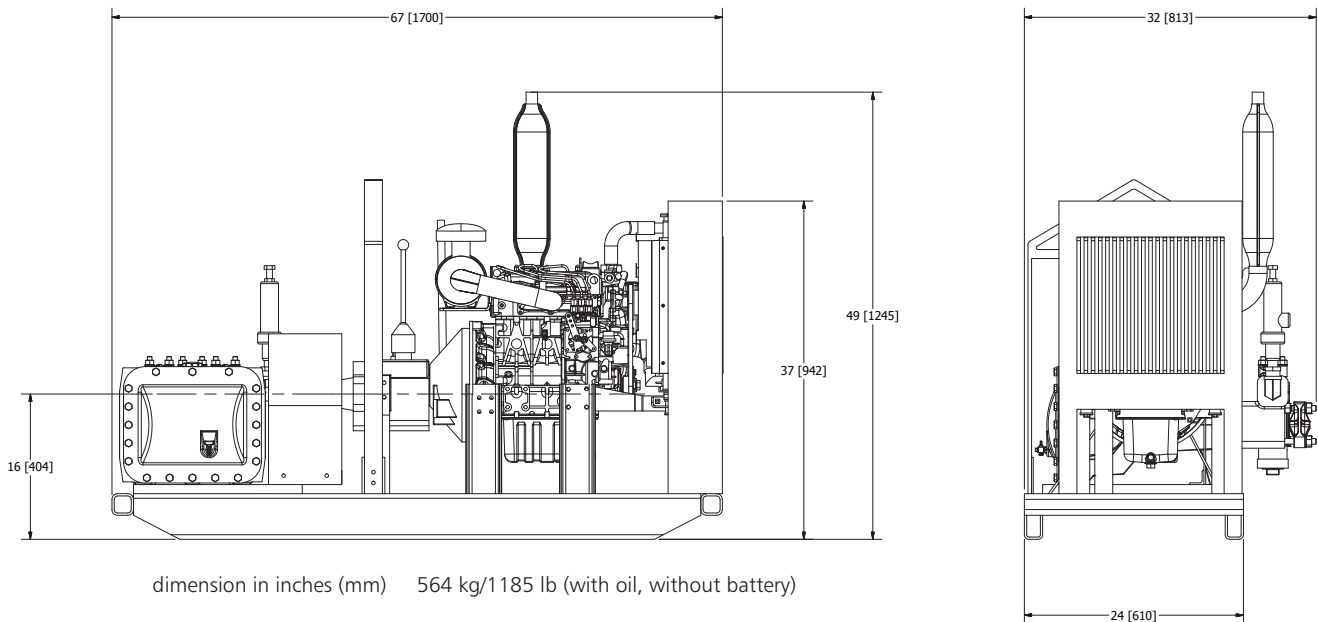

www.frontierpower.com

Delta BC	604-946-5531
Edmonton AB	780-455-2260
Calgary AB	403-720-3735
Winnipeg MB	204-949-1526

Mudmaster 435DT Pump Unit



Diesel powered FMC (Bean) pumping unit designed for reliable service as a supply or pressure pump for core drilling. The diesel engine drives through a four speed transmission that is coupled to an FMC triplex piston pump. The pump can be operated with ball type valves for use with drilling mud or with disc type valves for use as a supply pump.

- The output rating of the pumping unit with ball valves is 37 US gpm @ 1000 psi (141 L @ 68 bar)
- The output rating of the pumping unit with disc valves is 50 US gpm @ 1000 psi (190 L @ 68 bar)

Standard Features

- Liquid cooled diesel engine
- Mudmaster 4 speed transmission
- FMC (Bean Royal) pump assembly
- Heavy gauge removable radiator guard
- Exhaust silencer (shown in vertical position)
- Dry type air filter with replaceable element
- Bolt-on single point lifting bail
- Gear selector
- Clutch actuator
- Adjustable pressure relief valve
- Welded structural tube skid base
- Spin-on replaceable fuel filter
- Primary fuel filter/water separator
- Start/Stop water resistant panel
- Battery rack & cables
- Throttle control
- Heavy-duty coupling with safety cover
- Removable coupling guard

Flow Rates (per minute)

Ball valves:

- First gear - up to 11.3 US gpm (43 L)
- Second gear - up to 16.4 US gpm (62 L)
- Third gear - up to 29 US gpm (112 L)
- Fourth gear - up to 37 US gpm (141 L)

Disc valves:

- First gear - up to 15 US gpm (57 L)
- Second gear - up to 22 US gpm (83 L)
- Third gear - up to 39 US gpm (147 L)
- Fourth gear - up to 50 US gpm (190 L)



Mudmaster 435DT Pump Unit

Engine

- Kubota three cylinder, liquid cooled diesel engine
- Rated 23 intermittent BHP @ 3000 rpm
- Worldwide parts and service support
- Glow plug assisted starting
- Replaceable spin-on lube and fuel filters
- Dry type replaceable air filter
- Starting panel
- Throttle control
- Fuel transfer and priming pump
- Exhaust silencer
- Engine details are available on a separate spec sheet

Transmission

- Mudmaster transmission with integral reduction gear
- Four forward speeds provide pump input speeds of 169, 244, 440 and 733 rpm at 2200 engine rpm
- 8" automotive clutch assembly directly connected
- Spicer type output flange positively aligned to heavy duty pump coupling with removeable guard
- Gear selector
- Clutch activator

Pump

- FMC (Bean Royal) model W1122B-CD pump
- More than fifty years of continuous production
- Thousands in service around the world
- Rated 37 US gpm @ 1000 psi (140 litres @ 68 BAR) with standard "core drill" style ball valves
- Rated 50 US gpm @ 1000 psi (190 litres @ 68 BAR) with optional disc valves
- Actual flow rates may vary with the site conditions

Features

- Welded structural steel base frame with coped ends for ease of transport and installation
- Fuel transfer and priming pump
- Easy access for service and maintenance
- Adjustable pressure relief valve with steel plumbing
- Fully load tested and serviced including lube oil and antifreeze
- One set of owner's manuals
- Enamel paint finish

Options

- Fuel storage tank
- Starting battery (Group 24)
- Hydraulic drive system
- Air motor drive system
- Air cooled diesel engine
- Custom paint colours
- Spare parts kit
- Other options by request

